

SELF-PRIMING SEWAGE PUMP



TZW SAERIES

PUMP KEY

TZW S 80 - 40 - 16

TZW-Self-priming Sewage Pump
S-Stainless Steel (None-Cast Iron)
80-Suction Diameter (mm)
40-Rated Capacity (m³/h)
16-Rated Head (m)

TZW-series pump, self-priming & non-clog pump, is designed for pumping of municipal and industrial sewage and exhaust dejector or liquids containing fibers and scraps etc.

DESCRIPTION

* ASP TZW Series Non-Clogging Self Priming Solid Handling Pump handles a wide range of heavy duty pumping problems for various industries.

* It offers great design flexibility. This pump can be mounted high and dry above the liquid.

* It do not need to install a check valve and draw water into the pump. Furthermore it can suck or discharge medium which contains large solid and fibre.

* The pumps are capable for handling solids and stringy materials easily.

APPLICATIONS

* Such as paper pulp, engine plants, chemical industries, power station, mining, aquacultural, canneries, tanneries, meat packing plants, spinnery, food processing, etc.

* Any solids laden products- pulp, process water, filter waste, waste water, sludge and slime, etc.

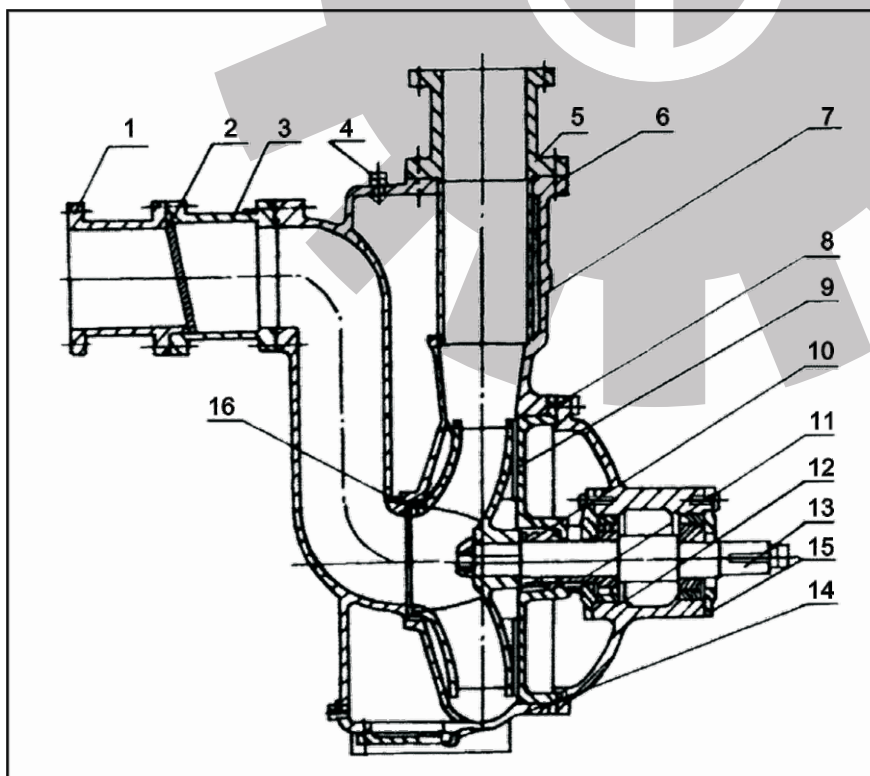

1. Inlet Pipe
2. Inlet Valve
3. Suction Flange
4. Water Fill-in Plug
5. Outlet Pipe
6. Pump Casing
7. Liquid-gas Separation Pipe
8. Back Cover
9. Impeller
10. Mechanical Seal
11. Deflector
12. Bearing Housing
13. Pump Shaft
14. Bearing Cover
15. Bottom Plate
16. Bolt