

MIXED-FLOW PUMP



STRUCTURE

◆ Single stage volute-type pump

FEATURE

- ◆ Compact structure
- ◆ Low head and large capacity
- ◆ Light weight
- ◆ Simple installation
- ◆ Simple maintenance
- ◆ Reliable operation
- ◆ Effective & efficiency

WORKING CONDITIONS

◆ Applicable handling clear water or similar liquids at temperature below 80°C

APPLICATIONS:

- ◆ Irrigation and drainage of farmland
- ◆ Water supply and discharge in industry and urban areas

RANGE

SIZE: 80 – 650mm

CAPACITY: 36m³/h – 3800m³/h

STRUCTURE

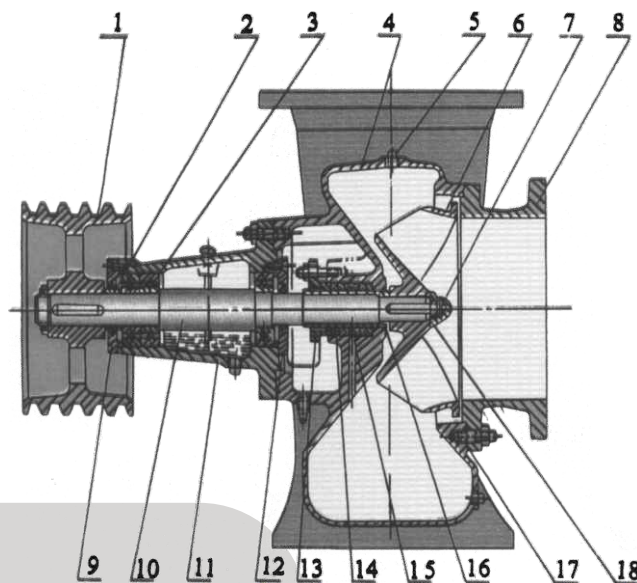

1. Pulley
2. Spacer sleeve
3. Bearing
4. Pump body
5. Square-head screw plug
6. Impeller
7. Impeller nut
8. Pump cover
9. Back cover
10. Pump shaft
11. Bearing body
12. Front cover
13. Packing gland
14. Packing
15. Packing retaining ring
16. Shaft sleeve
17. Paper gasket
18. Washer



MF SERIES

