

HEAVY DUTY SLURRY PUMP

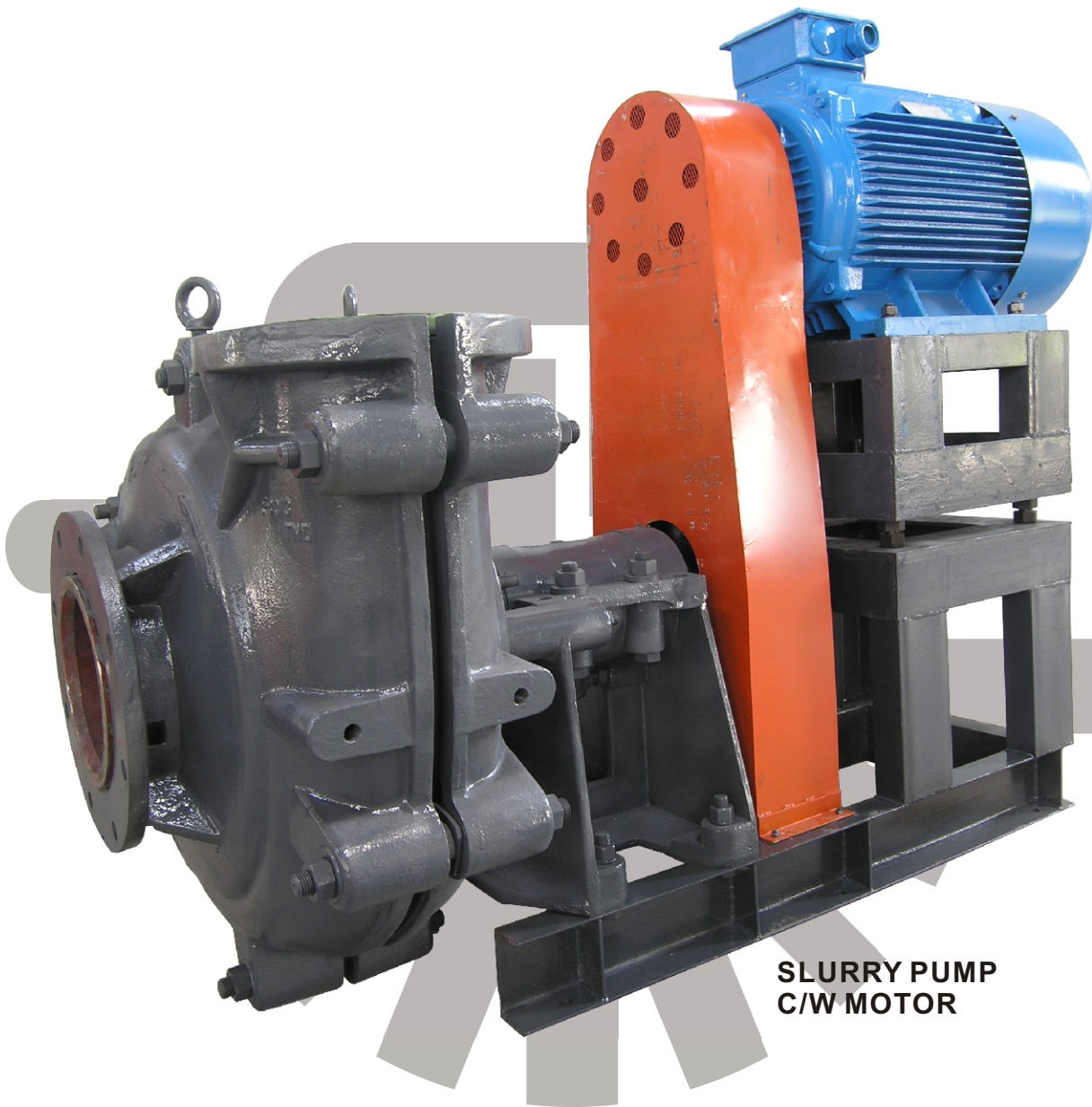

**SLURRY PUMP
C/W MOTOR**



THONG FATT JAYA MACHINERY HARDWARE SDN. BHD.

同發機械五金有限公司 (176024-V)

775-779, Jalan Kuala Kangsar, Taman Tasek Jaya,
31400 Ipoh, Perak, Malaysia.
Tel: 00-605-5468 659, 5455 751, 5479 196, 5454 107
Fax: 00-605-5482 282, 5474 753
Email: tfjaya@tm.net.my / tfjaya@streamyx.com
Website: <http://www.thongfattjaya.com.my>

HEAVY DUTY SLURRY PUMP



Pumps are available either Rubber or Metal lined utilizing Abrasive and Corrosive Resistant Materials.

Cartridge Bearing Assembly and Shaft

- The shaft is designed with a short overhang to:
 - *Reduce shaft deflection
 - *Minimize vibration
- Provided with hardened shaft sleeve to protect the shaft
- Optional dimensionally interchangeable heavy duty bearing cartridge assemblies
- Cartridge assembly is retained on one piece frame
- Grease purged piston rings to help seal contaminants out of bearing housing

Impeller

- Enclosed impellers to maximize efficiency
- Pump out vanes on both shrouds
 - *Minimizes recirculation
 - *Reduces stuffing box pressure
- Hard Metal or Elastomer liquid ends
- Interchangeable hard metal and elastomer impellers
- Cast-in impeller threads to protect shaft
- Impeller clearance set by moving cartridge assembly



Hi-chrome iron castings being poured

Double Casing with Radial Split Outer Casing

- Ease of assembly and disassembly of liquid end
- Optional ductile iron construction for higher working pressures
- Removable liners are positively attached with fasteners

Dynamic Seals

- Reduces or eliminates need for seal water
- Reduces sleeve wear and possible bearing failure

Removable Liners

- Liners are positively attached utilizing studs

Configuration and Materials Options

	STANDARD	OPTIONAL
LINERS	Chrome Alloy	Special pH
	Natural Rubber	Alloy Urethane
IMPELLERS	Chrome Alloy	Special pH
	Natural Rubber	Alloy Urethane
CASING	Cast Iron	Ductile Iron
SHAFT SEAL	Packed Box Full	Expeller
	Low Flow	Mechanical Seal

An option heavy duty bearing assembly is available from Atlas Pumps for applications where additional power or bearing loading is required.

STD. CARTRIDGE ASSY		HD. CARTRIDGE ASSY	
Size	BHP/KW Max	Size	BHP/KW Max
C1	40/30	CC1	75/55
D1	80/60	DD1	150/110
E1	160/120	EE1	300/225
F1	350/260	FF1	570/425



THONG FATT JAYA MACHINERY HARDWARE SDN. BHD.

同發機械五金有限公司 (176024-V)

775-779, Jalan Kuala Kangsar, Taman Tasek Jaya, 31400 Ipoh, Perak, Malaysia.
 Tel: 00-605-5468 659, 5455 751, 5479 196, 5454 107
 Fax: 00-605-5482 282, 5474 753
 Email: tfjaya@tm.net.my / tfjaya@streamyx.com
 Website: <http://www.thongfattjaya.com.my>

HEAVY DUTY SLURRY PUMP



ASP Pump liner and impeller material have interchangeable wear part combinations.

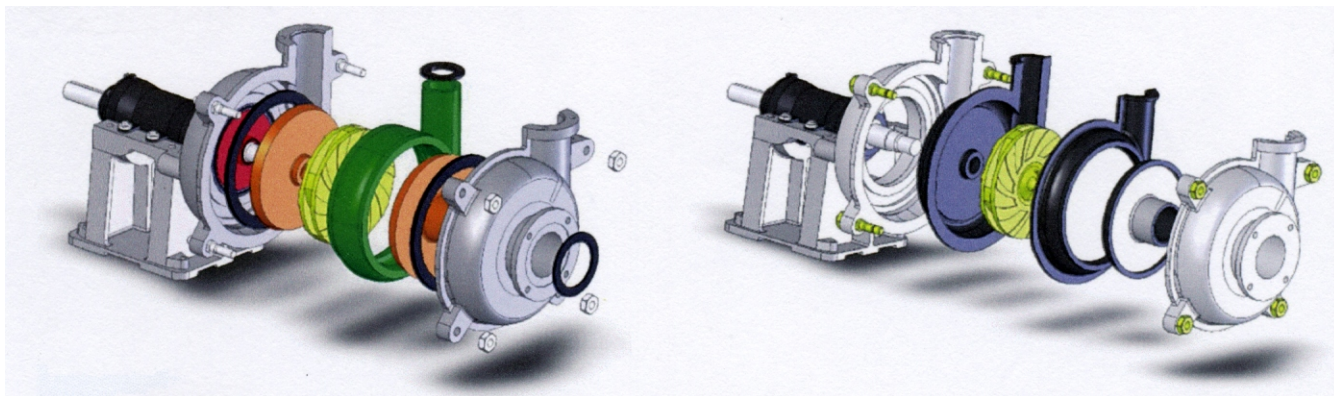

Liners and Impellers for hard metal and elastomeric lined pumps have common dimensions and are interchangeable within the same pump size.

Frame supports the bearing cartridge which includes grease lubricated taper roller or cylindrical bearings. Bearings are located on a large diameter shaft designed to minimize overhang and deflection.

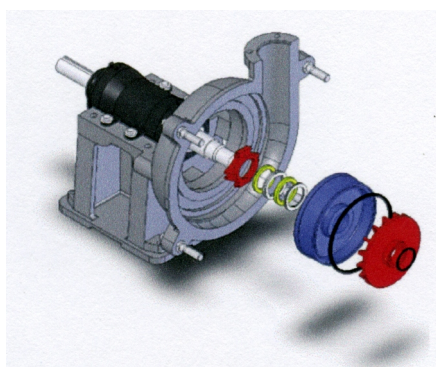

For conventional packed box and lantern ring construction, sealing water must be provided at a minimum of 10 PSIG above discharge pressure to insure positive flow.

Where suction conditions allow, ASP Pump expeller seal can eliminate the need to supply water to the stuffing box. Where high suction pressures or series pumping is desired other methods of sealing must be utilized.

Expeller and expeller ring are constructed from Hi-Chrome material.

Shaft sleeve material is 420 SS hardened to 550 Brinell to protect the shaft from wear.

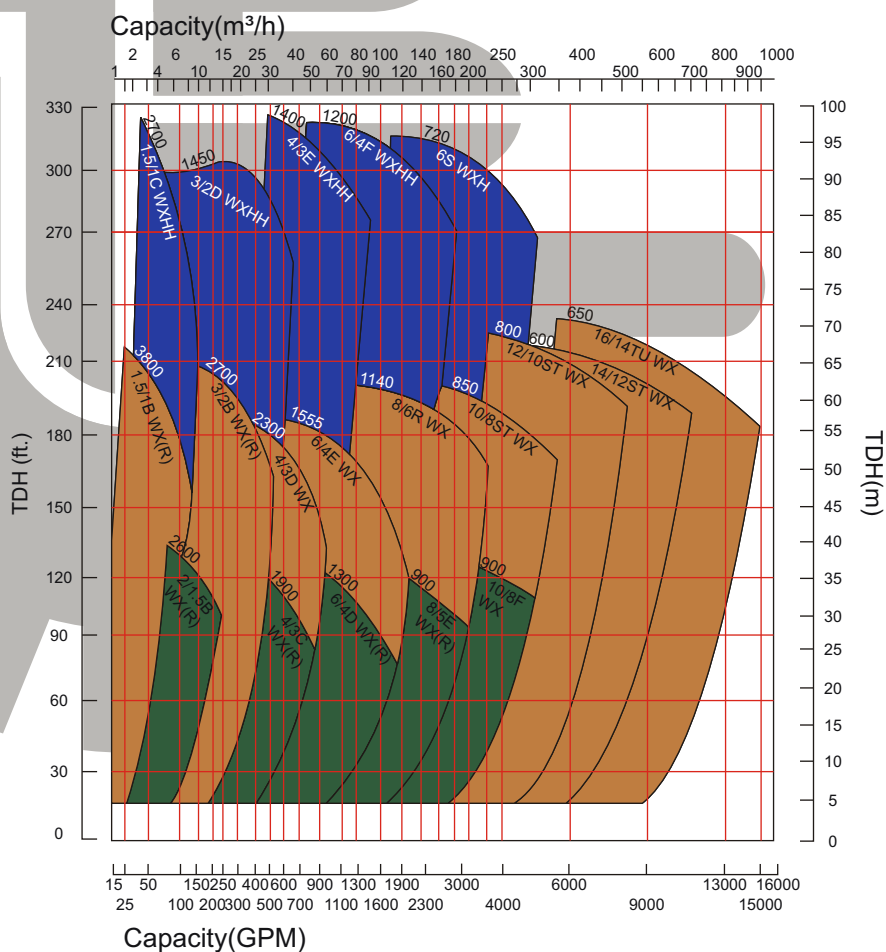

THONG FATT JAYA MACHINERY HARDWARE SDN. BHD.

同發機械五金有限公司 (176024-V)

775-779, Jalan Kuala Kangsar, Taman Tasek Jaya, 31400 Ipoh, Perak, Malaysia.
Tel: 00-605-5468 659, 5455 751, 5479 196, 5454 107
Fax: 00-605-5482 282, 5474 753
Email: tfjaya@tm.net.my / tfjaya@streamyx.com
Website: http://www.thongfattjaya.com.my

Dimension For AH Slurry Pump

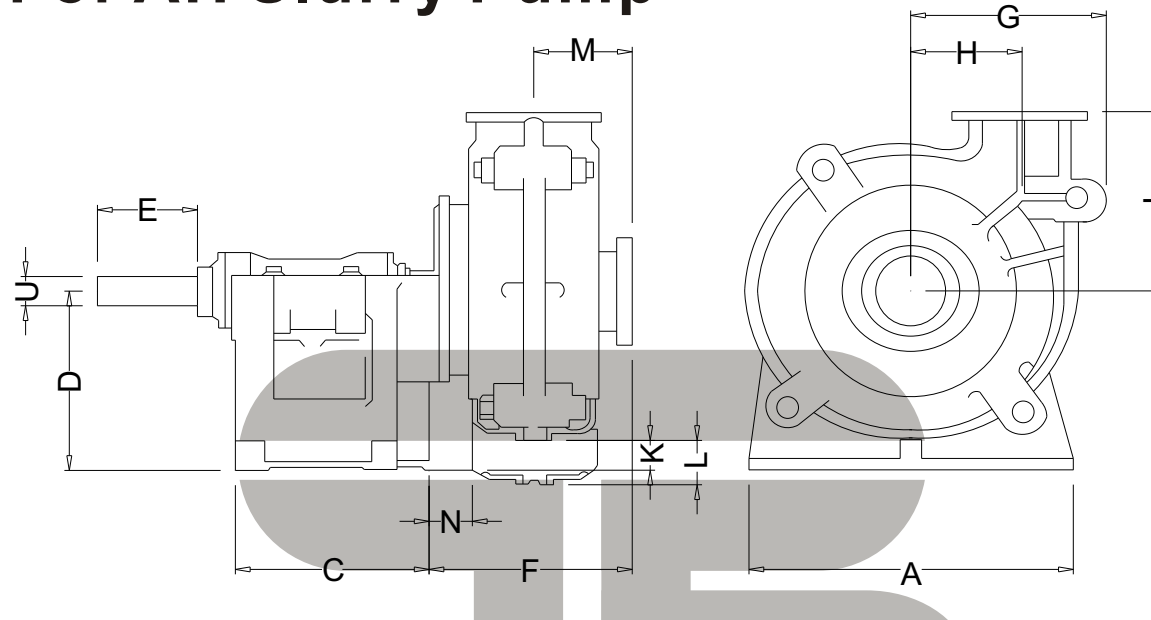

Pump Size	A	B	C	D	U	E	F	G	H	J	K	L	M	N	V	T	S	n-d	Intake Flange				Discharge Flange				WT (kg)	
																			D0	D1	D2	n-d1	d0	d1	d2	n-d2	Metal	Elastomer
1.5X1B-WX	583	295	248	197	28	79	206	181	98	171	46	-	143	254	181	38	24	4-ø14	152	38	114	4-ø16	165	25	127	4-ø16	91	77
1.5X1C-WXH	759	406	311	254	42	121	306	270	194	254	-	11	175	356	252	48	32	4-ø19	152	38	114	4-ø17	152	25	114	4-ø17	318	-
2X1.5B-WXH	592	295	248	197	28	79	217	205	114	184	33	-	143	254	184	38	24	4-ø14	184	51	146	4-ø19	165	38	127	4-ø19	104	118
3X2C-WX	768	406	311	254	42	121	281	238	138	210	71	-	175	356	233	48	32	4-ø19	216	76	178	4-ø19	184	51	146	4-ø19	191	154
3X2D-WXH	986	492	364	330	65	164	389	384	254	368	-	51	213	432	298	64	38	4-ø22	216	76	178	8-ø19	203	51	165	4-ø19	750	-
4X3C-WX	843	406	311	254	42	121	354	292	149	262	24	-	175	356	270	48	32	4-ø19	279	102	235	4-ø22	229	76	191	4-ø22	263	236
4X3D-WX	943	492	364	330	65	164	353	292	149	262	100	-	213	432	279	64	38	4-ø22	279	102	235	4-ø22	229	76	191	4-ø22	363	290
4X3E-WXH	1240	622	448	457	80	222	492	492	330	432	2	-	257	546	381	76	54	4-ø29	254	102	210	8-ø19	254	76	210	8-ø19	1250	-
6X4D-WX	1021	492	364	330	65	164	421	406	229	338	11	-	213	432	318	64	38	4-ø22	337	152	292	4-ø22	279	102	235	4-ø22	626	454
6X4E-WX	1178	622	448	457	80	222	433	406	229	338	138	-	257	546	351	76	54	4-ø29	337	152	292	4-ø22	279	102	235	4-ø22	728	635
6X4S-WXH	1668	920	780	450	120	280	596	616	413	546	-	134	640	760	353	90	70	4-ø35	337	152	292	8-ø22	305	102	260	8-ø22	2880	-
8X6E-WX	1302	622	448	457	80	222	557	551	318	460	-	62	257	546	402	76	54	4-ø29	406	203	356	8-ø22	368	152	324	8-ø21	1473	982
8X6R-WX	1360	680	590	350	85	215	554	551	318	460	-	170	490	560	312	70	50	4-ø28	406	203	356	8-ø22	368	152	324	8-ø22	1655	1164
8X6T-WXH	2275	1150	1040	650	150	350	852	835	584	813	-	160	880	900	538	125	80	4-ø48	432	203	375	8-ø29	432	152	375	8-ø29	6586	-
10X8E-WM	1337	622	448	457	80	222	584	613	381	470	-	83	257	546	403	76	54	4-ø29	502	254	445	8-ø29	432	203	375	8-ø29	1625	1202
10X8R-WM	1395	680	590	350	85	215	582	613	381	470	-	190	490	560	314	70	50	4-ø28	502	254	445	8-ø29	432	203	375	8-ø29	1836	-
10X8ST-WX	1748	1150	780	650	120	280	692	673	419	635	27	-	620	900	439	125	80	4-ø48	502	254	445	8-ø29	432	203	375	8-ø29	3750	3130
12X10ST-WX	1816	1150	780	650	120	280	762	755	464	674	-	65	620	900	461	125	80	4-ø48	527	305	470	8-ø25	527	254	470	12-ø25	4318	3357
14X12ST-WX	1873	1150	780	650	120	280	812	937	629	832	-	224	620	900	486	125	80	4-ø48	585	356	521	12-ø25	552	305	495	12-ø25	6409	4672
16X14TU-WX	2320	1460	1050	900	150	350	953	1048	660	889	-	84	860	1200	597	150	95	4-ø79	705	406	641	8-ø35	673	356	610	12-ø29	10000	-
20X18TU-WX	2475	1460	1050	900	150	350	1100	1420	940	1230	-	420	860	1200	615	150	95	4-ø79	900	508	800	12-ø42	900	460	800	12-ø42	18864	15921
6S-WH	1700	920	780	450	120	280	622	625	415	615	-	155	640	760	382	90	70	4-ø35	380	152	320	8-ø27	420	150	360	8-ø27	3450	-